

CYCO[®]

OIL BURNER NOZZLE

Dongguan Changyuan Spraying Technology Co.,Ltd

Dongguan Changyuan Spraying Technology Co.,Ltd

Add:Xiabian Industrial Zone, Changan Town, Dongguan City, Guangdong Province, China
Tel:0769-81558036 81558041
Fax:0769-81558831
Email:dgey818@ecyco.cn
Website: www.penzuicn.com

COMPANY PROFILE

Dongguan Changyuan spraying technology co., ltd. divided from Dongguan Changyuan technology industrial co., ltd. on September 2012. Dongguan Changyuan technology industry co., ltd. was founded in 1998, is located in Dongguan city chang 'an town xiabian industrial zone, after more than 20 years of development, Changyuan has formed research and development, production, sales as one of the high-tech company. The company specializes in the production of all kinds of industrial spray spray products, varieties up to several thousand, with more than 5,000 customers, is one of the largest nozzle manufacturers in China. The company's senior management and Taiwan, Japan and other technical experts have long maintained a good relationship of cooperation. The company has dozens of Japanese automatic CNC computer lathes, precision up to 2 microns, has five axis machining center which aperture accuracy up to 0.1mm, has a high-pressure test bench and other precision particle size testing instruments, advanced equipment guarantee the quality improvement. Customers may choose engineering polypropylene, ceramics, alloys, imported 303, 304 or 316 stainless steel materials to manufacture nozzle according to the actual use environment.

The company's engineers and technicians have accumulated very rich experience in developing technology, and can provide very fast technical support according to the special requirements of customers. More than 90% of the company's metal materials are imported to ensure the long-term stability of products provided to customers.

The company has offices in Shanghai, tianjin, chongqing, Qingdao, wuhan, ningbo, changsha, xi 'an and kunming, which are directly managed by the dongguan headquarters and can provide more convenient services for our customers.

The company has passed the DQS- UL 1509001:2008 quality system and ISO14001:2004 environmental system certification, headquartered in dongguan, guangdong province, for the general taxpayer subject, management norms, strict system and can meet the needs of customers.



Advanced Equipment

Quality Assurance

Having dozens of Japan full automatic CNC computer lathe which accuracy can reach to below 2 micron, several five axis processing machines which orifice size accuracy can reach to 0.10 mm, high pressure test workbench and other precision measuring instruments, we assure our quality by those advance equipment. Customers can select raw material, polypropylene, ceramic, metal, imported stainless steel 303, 304 or 316, according to actual use environment.



OD SERIES BURNER NOZZLE

Product Introduction

OD fuel nozzle is a single fluid high-pressure atomizing burner nozzle, which is suitable for atomizing burning of light oil and heavy oil. This series have four different angles 45°, 30°, 60°, 80°, and 3 kinds of spraying pattern: solid (S) and half solid cone(B), hollow(H), the flow parameter is from 0.5 usgal to 35 usgal.

Features:

1. Light oil, heavy oil atomizing
2. Flow range is from 0.5 usgal to 35 usgal
3. 100% capacity test before packing

Order reference

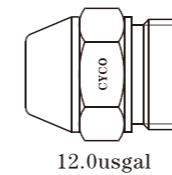
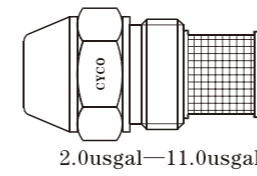
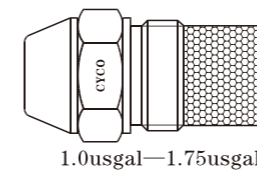
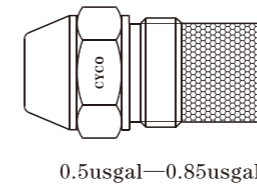
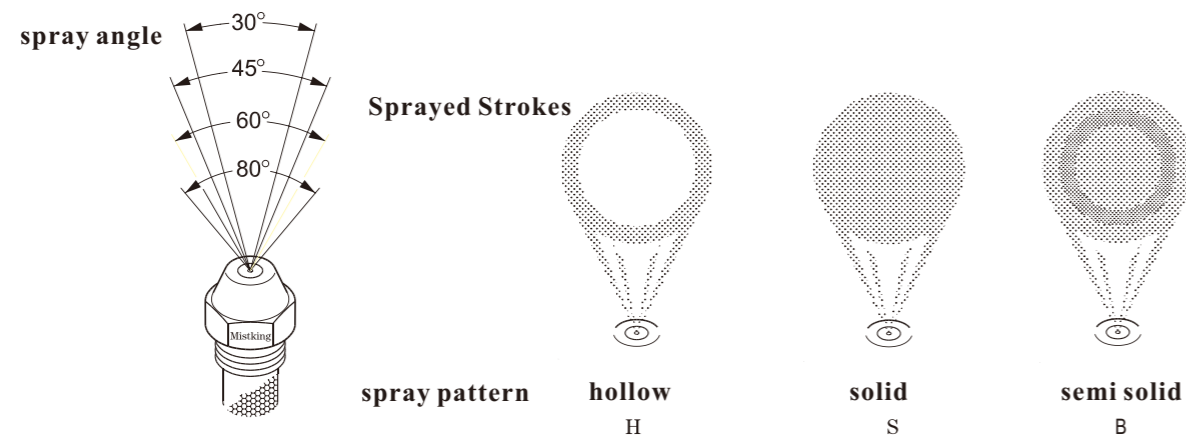
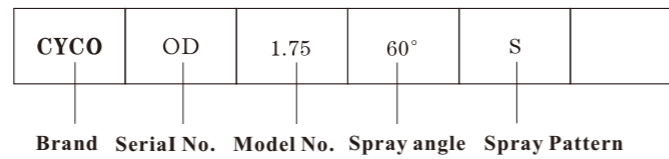

model	spray angle				rate of flow (10bar) kg/h
	30°	45°	60°	80°	
0.50	H S	H S	H S	H S	1.87
0.55	H S	H S	H S	H S	2.11
0.60	H S	H S	H S	H S	2.37
0.65	H S B	H S B	H S B	H S B	2.67
0.70	H S B	H S B	H S B	H S B	2.94
0.85	H S B	H S B	H S B	H S B	3.31
1.00	H S B	H S B	H S B	H S B	3.72
1.10	H S	H S	H S	H S	4.24
1.20	H S	H S	H S	H S	4.45
1.25	H S B	H S B	H S B	H S B	4.71
1.35	H S B	H S B	H S B	H S B	5.17
1.50	H S B	H S B	H S B	H S B	5.84
1.65	H S	H S	H S	H S	6.08
1.75	H S	H S	H S	H S	6.55
2.00	H S B	H S B	H S B	H S B	7.42
2.25	H S B	H S B	H S B	H S B	8.35
2.50	H S B	H S B	H S B	H S B	9.29
2.75	H S B	H S B	H S B	H S B	10.5
3.00	H S B	H S B	H S B	H S B	11.6
3.50	S	S	S	S	12.9
3.75	B	S B	S B	S B	13.8
4.00		S	S	S	14.2
4.50		S B	S B	S B	16.1
5.00		S B	S B	S B	18.5
5.50		S B	S B	S B	20.9
6.00		S B	S B	S B	23.4
6.50		B	B	B	26.1
7.00			S		27.9
7.50		B	B	B	29.8
8.00			S		31.5
8.50		B	B	B	33.1
9.00			S		35.4
10.00		B	B	B	37.7
11.00		B	B	B	42.5
12.00		B	B	B	47.7
13.50		B	B	B	54.3
15.00		B	B	B	60.4
17.00			B	B	67.4
19.50			B	B	76.2
22.00		B	B	B	86.4
25.00			B	B	96.7
28.00			B	B	109.5
31.50		B	B	B	122.5
35.00		B			133.5

Torque after installed

Nozzle mounting button	
Recommend installed torque	15-20Nm
Max. installed torque	25Nm

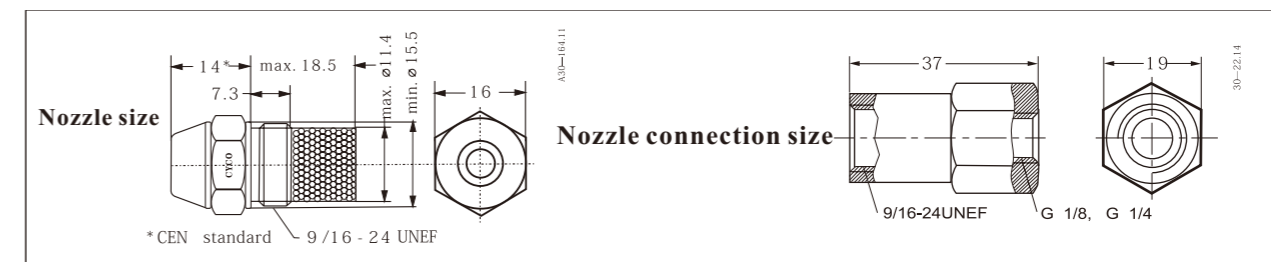

Siphon air atomizing oil nozzle

Product introduction

Siphon air atomizing nozzle is a kind of air atomizing nozzle that can create the best atomizing effect under low pressure. It is widely used in diesel oil, heavy oil, waste residue oil, animal and plant oil, alcohol-based fuel combustion machine system, as well as kerosene, oil atomization.

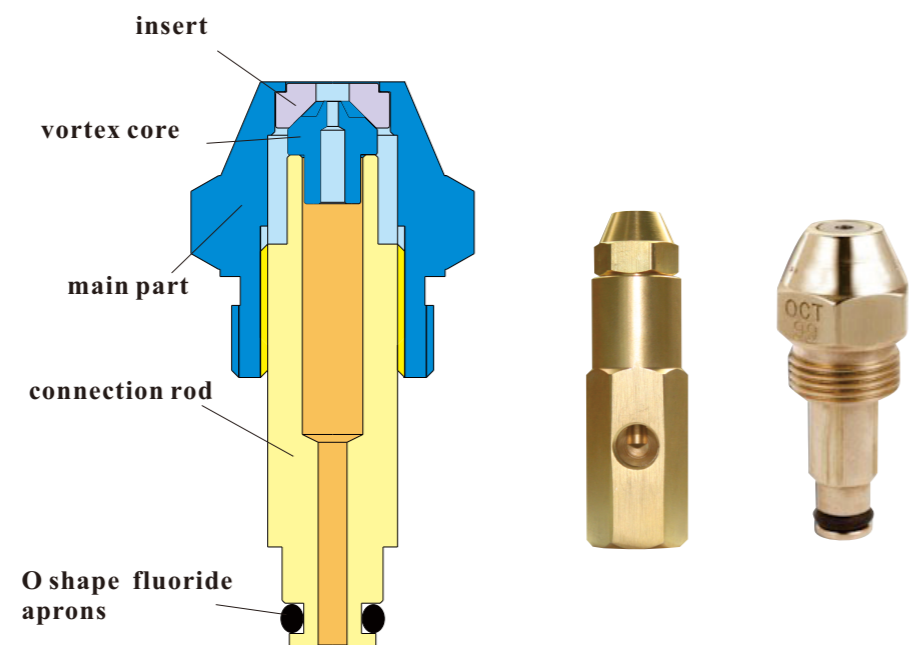

Product Technical Characteristics:

1. Atomizing and mixing oil droplet by using the cyclone of compressed air in the pipeline.
2. Small oil mist particles can be produced at low pressure and low gas volume.
3. Spray flow, angle and particle size can be adjusted by controlling air flow and pressure
4. Larger fluid channel, so there is a good anti-blocking effect
5. Excellent effect in liquid atomization of oil viscosity such as, heavy oil, waste oil combustion machine, oil.

Application:

It is widely used in diesel oil, heavy oil, waste engine oil, waste residue oil, animal and plant oil, alcohol-based fuel and other fuel, gas, combustion spray systems, workshop spray humidification and cooling systems, parts cleaning and dust removal, industrial spray products of various types.

Parameter

BURNER NOZZLE

Model No	Air Pressure 0.1Mpa Capacity Kg/h	Air Pressure 0.2Mpa Capacity Kg/h	Air Pressure 0.3 Mpa Capacity Kg/h	Height mm
MK-04	1.5	1.0	- -	200
MK-07	3.6	4.5	4.0	200
MK-09	4.0	5.5	5.6	200
MK-11	5.0	6.0	6.0	200
MK-13	5.5	6.5	6.6	200
MK-15	6.6	9	9.5	200
MK-19	13.0	18.0	21.0	200

Oil Atomization NOZZLE

Model No	Spiral Chute	Orifice Size	Insert	Air Pressure 0.2 Mpa Capacity Kg/h	Height mm
WN-01	4×0.8	Φ1.2	Φ3.0	10	200
WN-02	6×0.8	Φ2.0	Φ3.2	15	200
WN-03	6×0.8	Φ2.3	Φ3.5	20	200
WN-04	6×1.2	Φ2.5	Φ4.0	30	200

Back flow oil nozzle

Product introduction

The back-flow oil nozzle is a single fluid pressure atomizing nozzle which can adjust the spray capacity and angle. There is a channel inside for oil returning. When the returning oil valve is opened, part of the fuel can return to the tank through the channel. At the same time, the oil pressure in the front of the nozzle is basically unchanged, so the atomization effect of the nozzle is stable even when the capacity is changed.

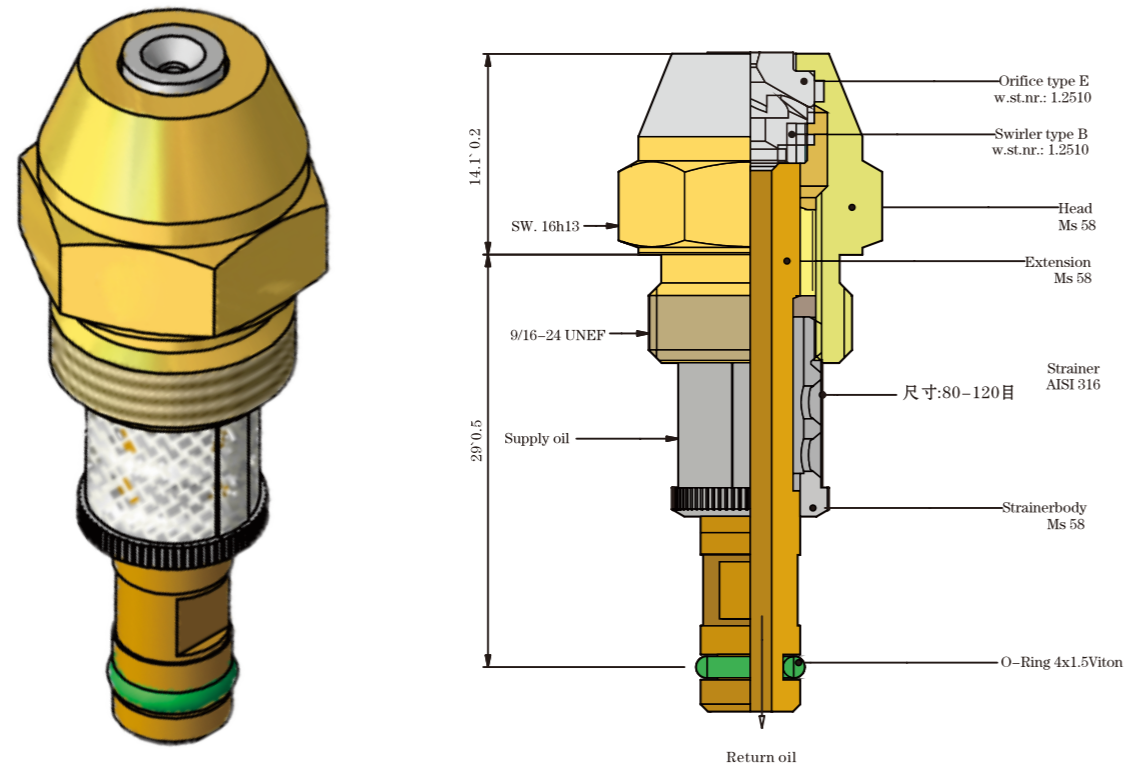

Application Characteristics

1. The capacity of the nozzle can be accurately controlled by oil returning pressure
2. Spray Angle range is small
3. Stable oil supply pressure, variable capacity, stable atomization effect
4. A wide range of capacity for options

Specification and Characteristics

1. Capacity: 20-750kg/h
2. Spray angle: 30° 35° 45° 50° 60° 70° 80°
3. Adjust ratio: 1:3-1:5

Energy nozzle

Product introduction

The energy nozzle is a pressure atomizing nozzle that can adjust the spray flow and angle. There are oil returning channels and thimble inside. When the oil return valve is opened, the area of oil returning channel can be changed by the thimble to control the oil returning volume and angle.

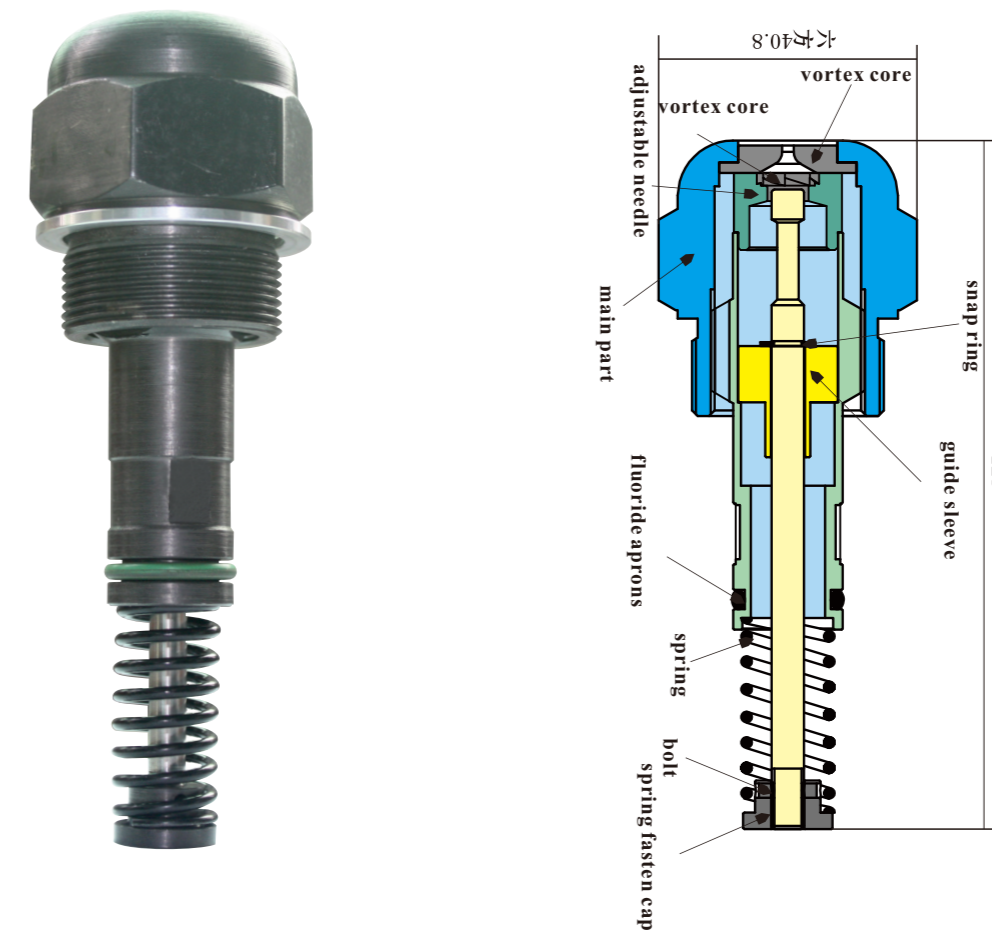

Characteristics

1. By changing the area of the return oil channel to control the volume of returning oil, so as to adjust the capacity of injection
2. Capacity: 600-2400kg/h
3. Spray angle: 45°

Methanol nozzle

Product introduction

Methanol nozzle is one of mechanical air atomizing nozzle designed by Changyuan. It combines the advantages of simple mechanical misting nozzle and high-pressure air flow misting nozzles, and eliminates each disadvantage by using a higher oil pressure and high speed gas to lower down the oil pressure and air consumption than the mechanical atomizing nozzle. So the adjustment ratio is expanded, atomizing performance is improved, also the gas consumption is saved

Product characteristics

1. Wide adjustable flow range
2. High accuracy of flow control
3. Excellent atomizing performance

Application and specification

Applied to burner system of light and heavy oil, alcohol-based fuel system.

Parameter

Model	Air pressure 0.3Mpa	Oil pressure 0.1Mpa	Air pressure 0.3Mpa	Oil pressure 0.2Mpa	Air pressure 0.3Mpa	Oil pressure 0.2Mpa
	Capacity kg/h		Capacity kg/h		Capacity kg/h	
JC-1	20		80		120	
JC-2	60		200		300	

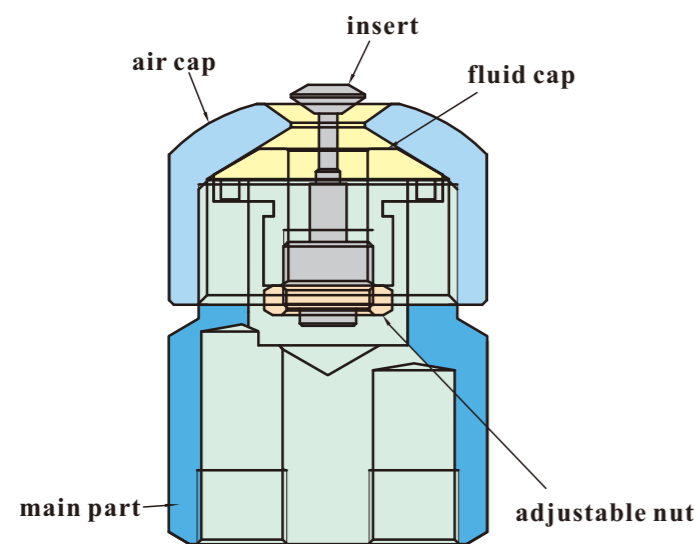

Asphalt nozzle

Product introduction

Asphalt nozzle is a new type of mechanical medium atomizing nozzle. Its structure includes a central pressure atomizing nozzle and an atomized air passage. Mainly used in asphalt tanker heating system.

Specification and application

It is mainly used in the combustion of heavy and light oil with large capacity

Parameter

Asphalt nozzle	Oil/Air Pressure 0.1Mpa	Oil/Air Pressure 0.15Mpa	Oil/Air Pressure 0.2Mpa	Oil/Air Pressure 0.25Mpa	Oil/Air Pressure 0.3Mpa
Capacity KG/H	450	740	850	960	1100

